

Ambience Roller Blind

Product Information

Ambience Roller Blind offers a robust system utilising the new generation hardware system, the Ambience Roller Blind incorporates many advanced features such as spring assist, easy installation and a range of accessories.

The Ambience Roller Blind is suitable for both commercial and residential use, available as either chain control or motorised operation.

Further Information

To find out more information phone Verosol Customer Care on 1800 721 404 or visit www.verosol.com.au



Technical Information

Product Code	R200.0	
Product Name	Ambience Roller Blind	
Operation	Stainless Steel Chain Operation	
Dimensions	Width	300mm minimum - 3000mm maximum
	Drop	300mm minimum - 3000mm maximum
	Spring Assist	850mm minimum width
	Maximum Area	6m ² without spring assist / 8m ² with spring assist
Roller Tube	Standard	44mm - for all roller blinds less than 2399mm wide
	Heavy Duty	49mm - for all roller blinds more than 2400mm wide
Base Rail Options	Flat [11mm x 22mm], Round [22mm], Verosol [17mm x 28mm] or Elliptical [11mm x 22mm]	
	Colours	Paint: White, Black and Barley Anodised: Clear
Control	Mechanism	Direct action, high tensile cold steel spring which operated in such a way that it only applies the precise braking power necessary to keep the blind in the desired position.
	Idler	Extendable pin idler-end for easy installation. The idler-end extends up to 10mm in increments of 1mm for improved installation.
	Colours	Paint: White, Black and Barley Anodised: Clear
	Chain	PVC, Nickel Plated Steel or Stainless Steel
Brackets	Material	Press formed steel, pre-treated and powder coated
	Colours	White, Black, Barley and Silver Grey

Turn over for motorisation and optional extras

Ambience Roller Blind

Motorisation

Product Code	R200.6	
Product Name	Ambience Roller Blind	
Operation	240V AC Motorised	
Dimensions	Width	600mm minimum - 3000mm maximum
	Drop	300mm minimum - 3000mm maximum
	Maximum Area	9m ²
Roller Tube	Standard	44mm - for all roller blinds less than 2399mm wide
	Heavy Duty	49mm - for all roller blinds more than 2400mm wide
More Information	Refer to "8.0 Motorisation" in your Verosol Price List for more information	

Optional

Guide Wires	Angle	15° angle from vertical	
	Maximum Area	6m ²	
Headbox Options	Type	QS8 Cassette Headbox	ACM Headbox
	Material	Extruded Aluminium Alloy [T5 Temper]	Extruded Aluminium Alloy [T5 Temper]
	Dimensions	90mm x 90mm	87mm x 90mm
	Maximum	4800mm maximum width	4800mm maximum width
	Colours	White, Black, Barley and Clear Anodised	White, Black, Barley and Clear Anodised
Fascia Options	Type	QS8 Fascia	
	Material	Extruded Aluminium Alloy [T5 Temper]	
	Dimensions	84mm x 82mm	Suitable for Face Fixing
	Maximum	4800mm maximum width	
	Colours	White and Clear Anodised	

System Diagrams

Ambience Roller Blind

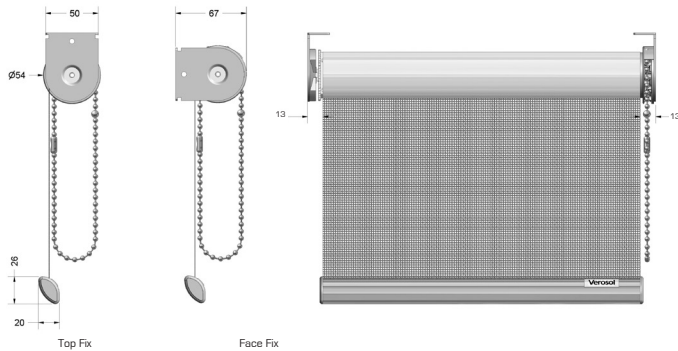

Ambience Roller Blind with Headbox

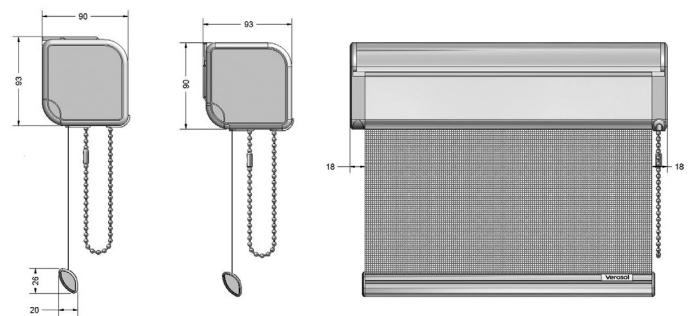

Standard Cassette

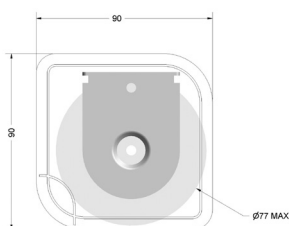

Round Front Cover

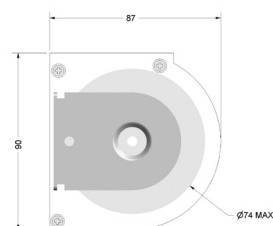

Fascia

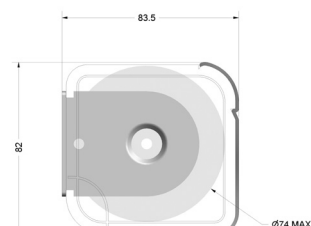

Visit Verosol Price List for more system diagrams